

# CERAMIC SMD MICROPROCESSOR CRYSTAL

ABM2

Pb in Glass  
(exempt per RoHS 2002/95/EC Annex (5))

**RoHS**  
Compliant



8.0 x 4.5 x 1.4mm

## FEATURES:

- Glass sealed ceramic package assures high reliability.
- Ceramic package assures high reliability
- Tight tolerance and stability available
- IR reflow capable

## APPLICATIONS:

- High density applications
- Modems, communication and test equipment
- PCMCIA, Wireless applications
- Microprocessor crystals

## STANDARD SPECIFICATIONS:

### PARAMETERS

ABRACON P/N:	ABM2 Series
Frequency:	7.000 MHz to 60.000 MHz
Operation Mode:	7.00 MHz - 50.00 MHz (Fundamental, AT-cut) 30.00 MHz - 60.00 MHz (3rd Overtone, AT-cut)
Operating Temperature:	- 10°C to + 60°C (see option)
Storage Temperature:	- 40°C to + 90°C
Frequency Tolerance:	± 50 ppm max. (see option)
Frequency Stability over the Operating Temp. (Ref to +25°C):	± 50 ppm max. (see option)
Equivalent Series Resistance:	See Table 1
Shunt Capacitance C <sub>0</sub>	5.0pF max.
Load Capacitance C <sub>L</sub>	18pF (see option)
Drive Level:	100µW max., 10µW Typical
Aging (per year) @ 25° C ± 3°C:	± 5ppm max.
Insulation Resistance:	500MΩ min. @ 100Vdc ± 15Vdc

Table 1

Frequency (MHz)	ESR(Ω) max.
7.00-9.999 (Fund.)	80
10.00 - 15.999 (Fund.)	60
16.00 - 50.00(Fund.)	50
30.00 -60.00 (3rd O/T)	80

## OPTIONS AND PART IDENTIFICATION:

(Left blank if standard)

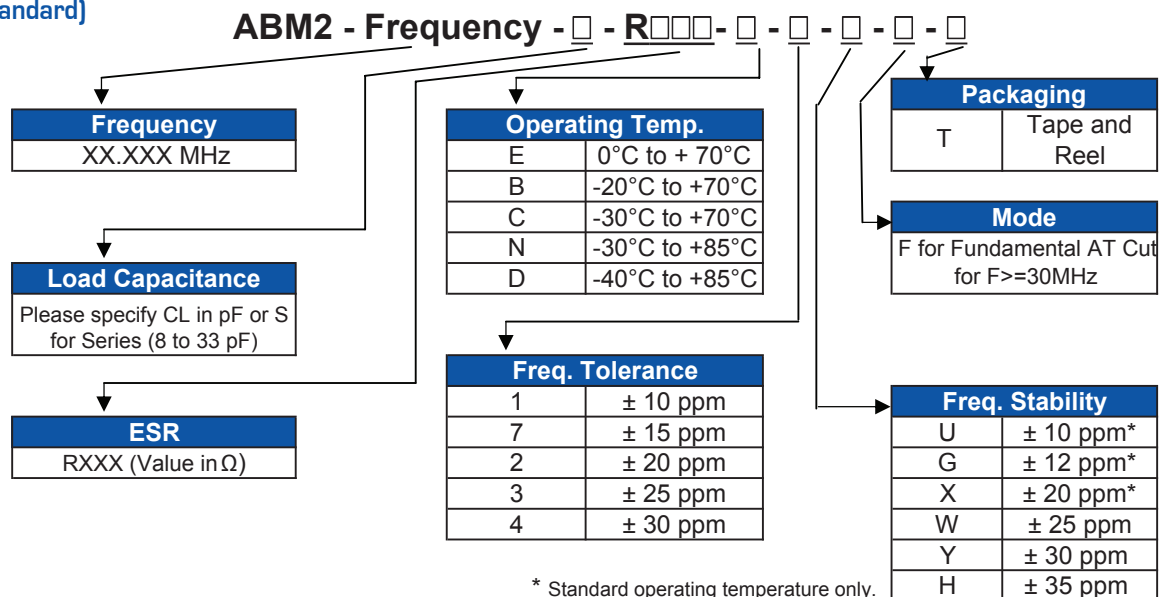

# CERAMIC SMD MICROPROCESSOR CRYSTAL

ABM2

Pb in Glass  
(exempt per RoHS 2002/95/EC Annex (5))

**RoHS**  
Compliant



8.0 x 4.5 x 1.4mm

## OUTLINE DRAWING:

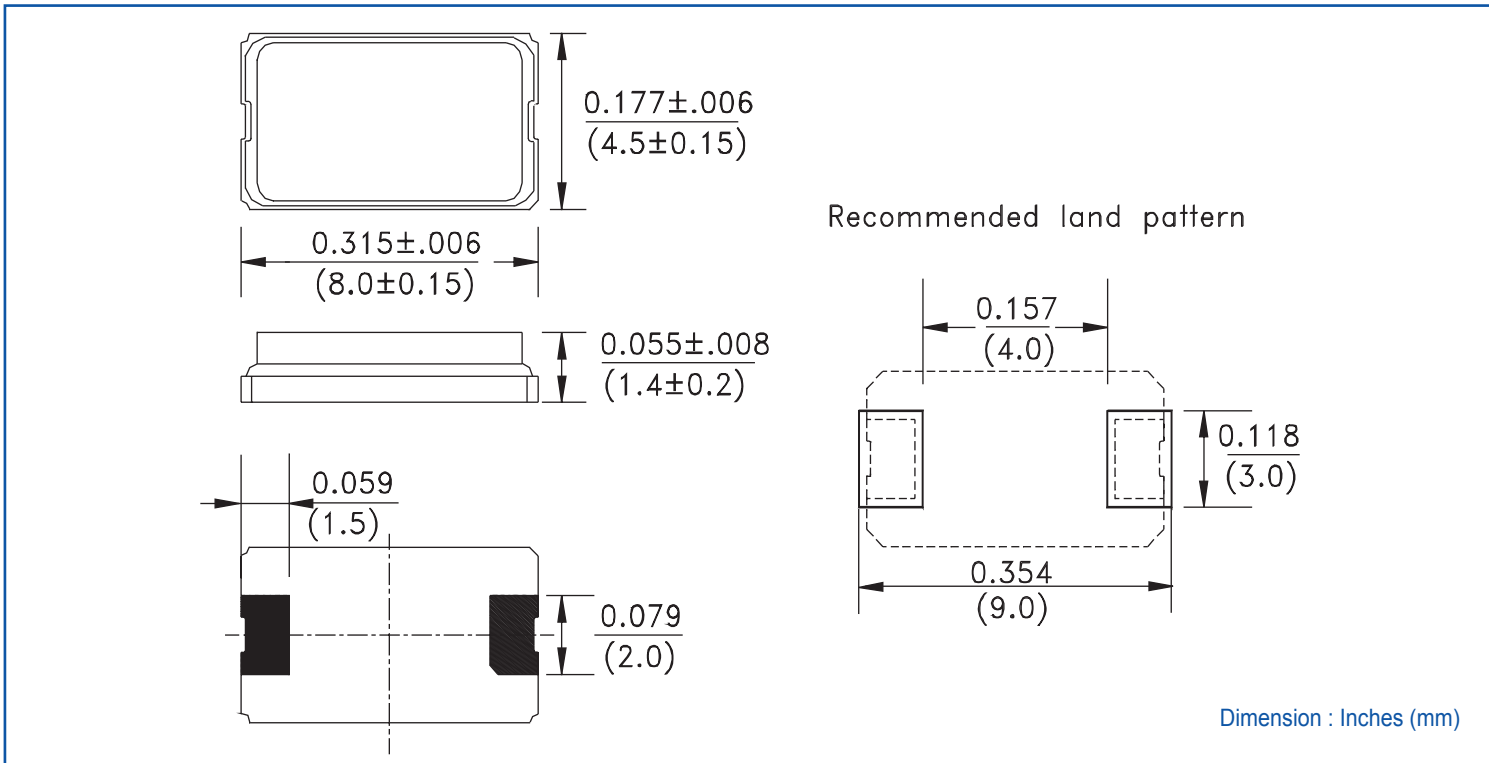

## TAPE & REEL: Tape and reel 1,000pcs/reel

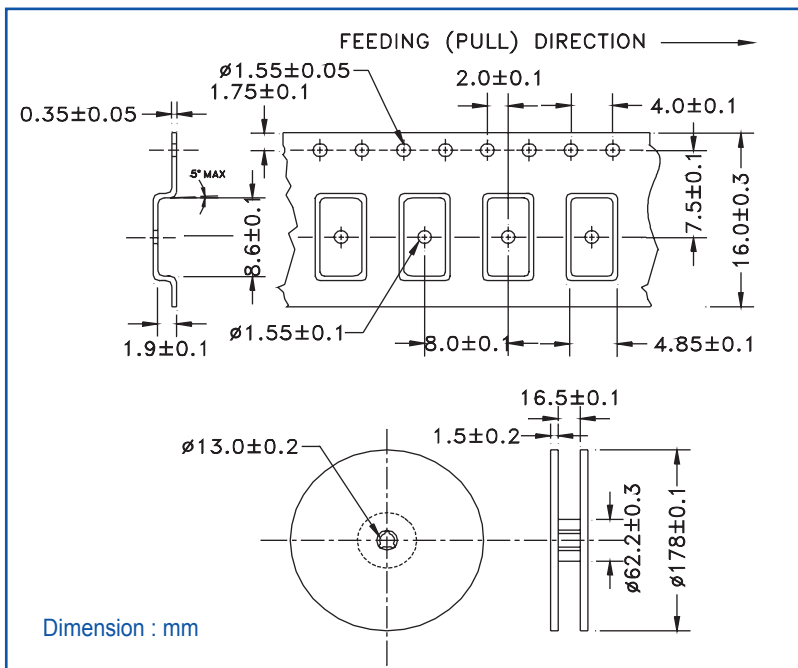

## REFLOW PROFILE

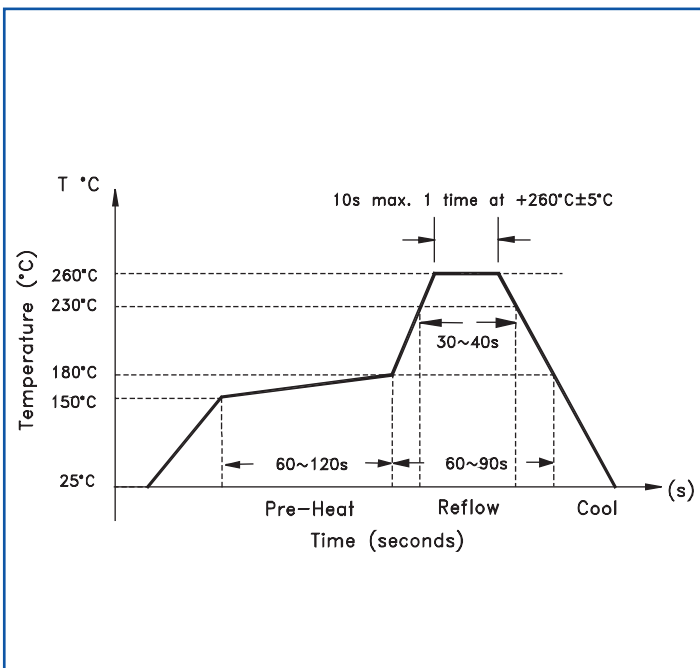

Need a test socket for the ABM2 Series? To view compatible **PRECISION TEST & BURN-IN SOCKETS** for these parts, [click here](#).

**ATTENTION:** Abracon Corporation's products are COTS - Commercial-Off-The-Shelf products; suitable for Commercial, Industrial and, where designated, Automotive Applications. Abracon's products are not specifically designed for Military, Aviation, Aerospace, Life-dependant Medical applications or any application requiring high reliability where component failure could result in loss of life and/or property. For applications requiring high reliability and/or presenting an extreme operating environment, written consent and authorization from Abracon Corporation is required. Please contact Abracon Corporation for more information.

ABRACON IS  
ISO 9001 / QS 9000  
CERTIFIED



Visit [www.abracon.com](http://www.abracon.com) for Terms & Conditions of Sale **Revised: 08.19.10**  
30332 Esperanza, Rancho Santa Margarita, California 92688  
tel 949-546-8000 | fax 949-546-8001 | [www.abracon.com](http://www.abracon.com)